



Product Specification

产品规格承认书

Customer Code 客户代码: _____

Customer Part Number.客户产品料号: _____

Coincell Battery Cell Model. 科恩瑟尔电芯型号: _____

M18360L1

Coincell Battery Part Number.科恩瑟尔产品料号: _____

207-10058-101

Prepared by 制作人	Checked by 审核人	Approved by 批准人
欧瑞先←	佟健↔	Valle Ye

Customer Approval 客户承认	Customer Signature/Date 客户签名/日期	Customer Company Stamp 客户公司盖章

深圳市科恩瑟尔电池有限公司

地址: 中国广东省深圳市龙华区

大浪街道华荣路龙兴商业大厦 5008

Shenzhen Coincell Battery Co., Ltd.

Address: 5008 Longxing commercial building, Huarong Road, Dalang Street Longhua District,

Shenzhen City, Guangdong Province, China

Kelly Shu 0086-17620552786

Kelly.shu@coincell.cn

www.coincell.cn

Revision History 版本履历 表

Revision 版本	Description 内容描述	Issued by 发行人	Approved by 审批人	Date 日期
V1	首次发行 First Release	欧瑞先	佟健	2024/03/16



Contents 目录

1. Scope 概述:	4
2. Battery cell specification 电芯规格:	4
3. Environmental Characteristic 环境特性:	7
4. Safety Test 安全测试:	8
5. Performance and Test Criteria 电池性能和测试标准:	11
6. Use of Battery 使用电池:	14
7. Warranty 保证期:	14
8. Others 其他事项:	15

1. Scope 概述

This document describes the specification of rechargeable Li-ion battery cell which is designed and manufactured by **Shenzhen Coincell Battery Co., Ltd.** 这文件描述由**深圳市科恩瑟尔电池有限公司**设计制造的可充电锂离子电芯的规格。

2. Battery cell specification 电芯规格:

No.	Item 项目	Parameters 参数	
1	Battery cell model 电芯型号	M18360L1	
2	Minimum capacity 最小容量 (标准充放电流程, 0.5C/0.2C, 23±3°C)	1200mAh	
3	Typical capacity 典型容量 (标准充放电流程, 0.5C/0.2C, 23±3°C)	1230mAh	
4	Nominal voltage 标称电压	3.8V	
5	Shipment voltage 出货电压	3.6-3.8V	
6	Shipment Status of charge 出货容量状态	10%~40%	
7	Charge ending voltage 充电限制电压	4.35V	
8	Discharge ending voltage 放电终止电压	2.75V	
9	Maximum cell dimension 电芯最大尺寸 (Cell with sleeve, 含套管)	D: 18.40 mm H: 36.00 mm	
10	Cell weight 电芯重量	≤28g	
11	Cell Impedance 内阻	≤65mΩ	
12	Max charge current 最大充电电流	≤0.2C 240mA (4.35V)	0°C ≤ T ≤ 10°C
		≤0.5C 600mA (4.2V)	0°C ≤ T ≤ 10°C
		≤2.0C 2400mA (4.2V)	10°C < T < 45°C
		≤1.0C 1200mAh (4.35V)	10°C < T < 45°C
13	Max discharge current 最大放电电流	2.0C 2400mA	0°C < T ≤ 60°C
		0.5C 600mA	-20°C ≤ T ≤ 0°C
14	Operating temperature 工作温度范围	Charge 充电: 0-45°C Discharge 放电: -20-60°C	

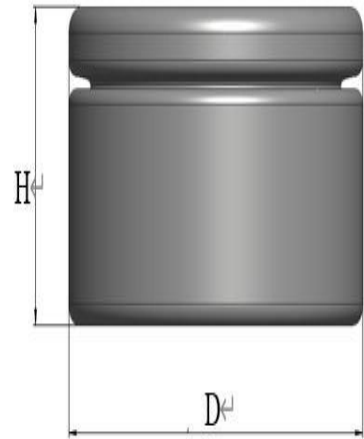



15	safely feature 安全特性	PTC、CID 和防爆阀集成在电池中 A PTC、CID and a vent are incorporated into the cell;	
16	Cycle life 循环寿命 (RT) (1200mA charge 充电, 600mA discharge 放电)	500 次充放电后, 电池恢复 80%的初始容量, 电芯尺寸无变化。 After 500cycles charge/discharge, battery can recover 80% of its initial capacity, No change in cell size .	
17	Storage Method 储存方式	1 Month at -20 to 60 °C, 30%SOC	Capacity Recovery Rate ≥ 85%
		3 Month at -20 to 45 °C, 30%SOC	Capacity Recovery Rate ≥ 90%
		1 Year at -20 to 35 °C , 30%SOC	Capacity Recovery Rate ≥ 90%
18	Certification requirement 认证要求	UL1642, BIS	

2.1 Cell printing 电芯喷码:

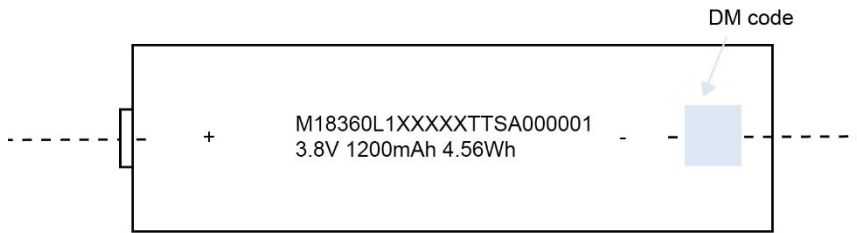

2.2 DM code: M18360L1XXXXTTSA000001

DM code 二维码内容:

M18360 L X X X XX TT S A 00001

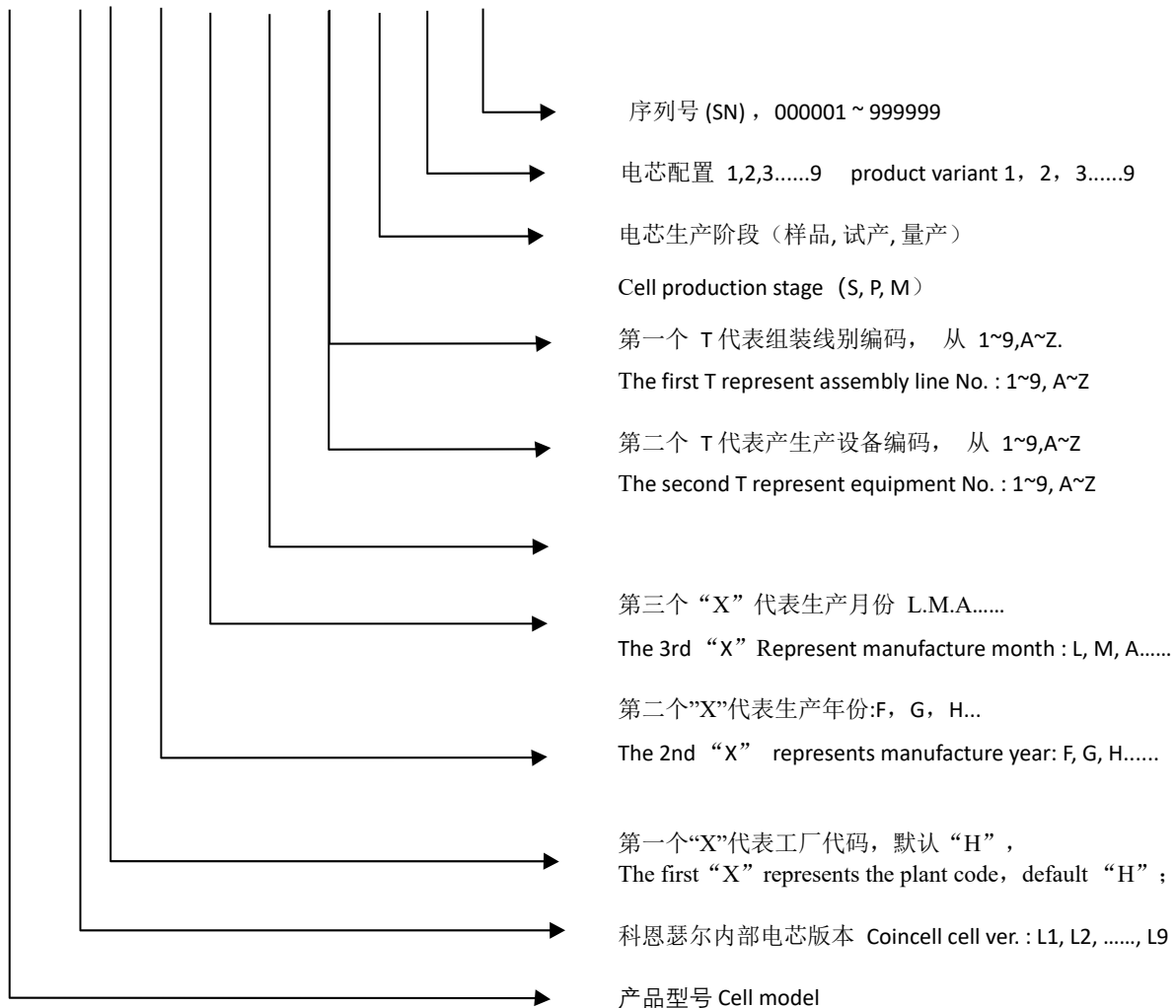

年份码号对照表

年份	2018	2019	2020	2021	2022	2023	2024	2025
码号	A	B	C	D	E	F	G	H
年份	2026	2027	2028	2029	2030	2031	2032	2033
码号	J	K	L	M	N	P	Q	R
年份	2034	2035	2036	2037	2038	2039	2040	2041
码号	S	T	U	V	W	X	Y	Z

月份码号对照表

月份	1	2	3	4	5	6
码号	A	B	C	D	E	F
月份	7	8	9	10	11	12
码号	G	H	J	K	L	M

2.3 Cell drawing 电芯示意图:

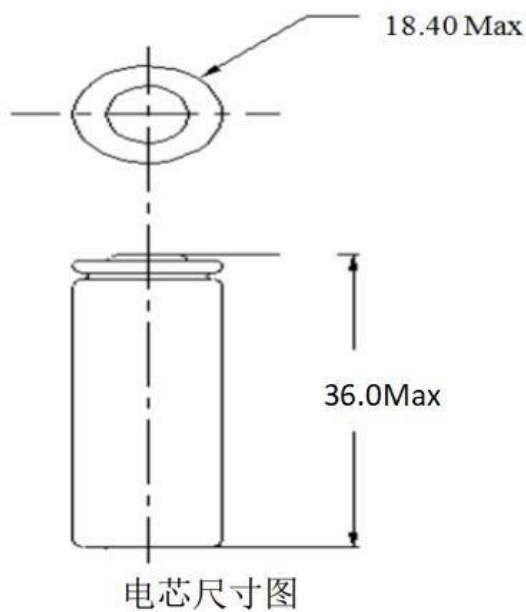

3. Environmental characteristics 环境特性

No.	Test item 测试项目	Test Method 测试方法	Pass Criteria 合格标准
1	Charged Storage Characteristics 荷电保持能力	Battery cell is fully charged by standard charge process. Battery cell idle at 23±3°C for 28 days. At 23±3°C, battery cell is discharged by 0.2C until 2.75V. 电芯按标准充电流程满充电。在 23±3°C 放置 28 天。在 23±3°C 电池按 0.2C 放电到 2.75V.	Capacity retention ≥ 80% initial; 容量保持率 ≥ 80%;
2	Discharge Characteristics under Different Temperature 不同温度下的放电性能	Tested the initial condition and initial capacity of battery by standard charge/discharge process at 23±3°C. Standard charge. Put the battery into 60°C/45°C/0°C/-10°C/-20°C for 2h, discharge by standard discharge process, Observe the appearance of the battery. 23±3°C下使用标准充放电流程，测量电池的初始容量和初始状态。电池标准充电后，在 60°C/45°C/0°C/-10°C/-20°C 条件下恒温搁置 2h、按标准放电流程测试放电容量，观察电池外观。	Discharge capacity / initial capacity *100% 60°C ≥ 95%; 45°C ≥ 100%; 0°C ≥ 80%; -10°C ≥ 70%; No change in appearance.



4. Safety Test 安全测试

Coincell battery can meet several international safety standards. Below is part of safety tests which are referred to international standard.

深圳市科恩瑟尔电池有限公司的电池能达到多个国际电池安全标准。以下是部分安全测试项目。

No.	Test item 测试项目	Test Method 测试方法	Criteria 标准
1	Constant Humidity and Temperature test 恒定湿热测试	Battery cell is fully charged by standard charge process. Then, battery cell is put into chamber with constant humidity (90~95%) and temperature ($40\pm 2^{\circ}\text{C}$) for 48hrs. After test, battery idle for 2hrs at $23\pm 3^{\circ}\text{C}$ and discharge by 0.2C to 2.75V. 电芯按标准充电流程满充电。之后电芯放在恒温箱 48 小时，湿度为 90~95%和温度为 $40\pm 2^{\circ}\text{C}$ 。测试后，电芯在 $23\pm 3^{\circ}\text{C}$ 搁置 2 小时，再按 0.2C 放电到 2.75V.	Capacity retention $\geq 60\%$ initial; No fire, No leakage, No explosion 容量保持率 $\geq 60\%$ ；无起火，无漏液，无爆炸
2	Overcharge Test 过充电测试	Battery cell is fully charged by standard charge process. Then, the battery is charged by 3.0C rate constant current and voltage to 4.6V for 7hrs. 电芯按标准充电流程满充电。之后电芯用 3C4.6V 恒流恒压充电 7 小时。	No fire, No explosion 无起火，无爆炸
3	Over discharge Test 过放电测试	At $23\pm 3^{\circ}\text{C}$, battery cell is discharged by 0.2C until 2.75V. And then battery cell is connected the load with 30Ω to discharge for 7hours. 电芯在 $23\pm 3^{\circ}\text{C}$ 用 0.2C 放电到 2.75V。之后电芯连接 30Ω 负载放电 7 小时。	No fire, No explosion 无起火，无爆炸



4	Short test 短路测试	<p>Battery cell is fully charged by standard charge process. Then, battery cell anode and cathode connected to $80 \pm 20 \text{m}\Omega$ load for 1 hour.</p> <p>电芯按标准充电流程满充电。电芯的正负极连接到 $80 \pm 20 \text{m}\Omega$ 负载 1 小时。</p>	<p>No fire, No explosion</p> <p>The Temperature of the Battery surface not exceeded than 150°C</p> <p>无起火, 无爆炸, 表面温度 $\leq 150^\circ\text{C}$</p>
5	Projectile Test 焚烧测试	<p>Battery cell is fully charged by standard charge process.</p> <p>Battery cell is placed on the screen which is to be constructed by steel wire mesh. The screen is mounted above the burner. And eight-sided covered wire cage is to be placed over the battery cell.</p> <p>Battery cell is to be heated and remain on the screen until it explodes or has been ignited or burned out.</p> <p>电芯按标准充电流程满充电。</p> <p>将电芯放在钢丝网上, 钢丝网下有燃烧器和钢丝网被八面铝网盖住。电芯在钢丝网上被加热直到电芯爆炸或被点燃或完全烧毁。</p>	<p>No part of an exploding cell shall penetrate the wire screen.</p> <p>电芯的任何部分不得穿出此八面铝网。</p>
6	Drop Test 掉落测试	<p>Battery cell is fully charged by standard charge process.</p> <p>Battery cell is free fall from a height of 1m on the cement floor, from X-axis、Y-axis positive and negative direction. Each direction is free fall 1 time.</p> <p>电芯按标准充电流程满充电。</p> <p>电芯从 1 米高处自由跌落到水泥地板上, 从 X 轴、Y 轴的正负方向, 每个方向自由跌落一次。</p>	<p>No fire, No explosion</p> <p>无起火, 无爆炸</p>
7	Shock test 撞击测试	<p>Battery cell is fully charged by standard charge process.</p> <p>Battery cell is secured to the testing machine by means of a rigid mount which will support all mounting surfaces of the battery cell. The battery cell is subjected to a total of two shocks of equal magnitude. The shocks are to be applied in each of two mutually perpendicular directions. For each shock the battery cell is accelerated in such a manner that during the initial 3ms the minimum average</p>	<p>No fire, No explosion,</p> <p>不起火, 不爆炸</p>



		acceleration is 75g. The peak acceleration shall be between 125 g and 175 g. Battery cell is tested at 20±5°C 电芯按标准充电流程满充电。在环境温度下，将电芯分别按二个轴向固定在测试台面上，前 3ms 内平均加速度最少达到 75g (g 为重力加速度)，峰值加速度达 125g 至 175g。电芯测试温度为 20±5°C	
--	--	---	--



5. Performance and Test Criteria 电池性能和测试标准

5.1 Standard Test Criteria 标准测试标准

If test criteria is not defined, test should be done under the below standard test criteria.

如果测试标准没有定义，测试标准会按以下测试完成。

Test Criteria 测试标准	Parameters 参数
Ambient Temperature 环境温度	23±3°C
Relative Humidity 相对湿度	65±20%
Atmospheric pressure 大气压力	86 ~ 106 kPa
Charge 充电	Standard charge process 标准充电流程
Discharge 放电	Standard discharge process 标准放电流程
Delivery Time from Coincell 从科恩瑟尔发出时间	Within 1month 一个月内

5.2 Visual Inspection 外观检查

No crack, no leakage, no rust

没有破裂，没有漏液，没有生锈

5.3 Measuring Instrument Standard 测量仪器标准

Instrument 仪器	Standard 标准
Instrument to measure dimension 测试尺寸仪器	Precision scale : 0.01mm 精度: 0.01mm
Voltmeter 伏特计	Internal impedance < 10kΩ/V 内阻 < 10kΩ/V
Ammeter 安培计	Impedance of ammeter and wires < 0.01Ω 安培计和电线内阻 < 0.01Ω
Impedance meter 阻抗计	Impedance is measured by sinusoidal 1kHz AC current 内阻测试用 1kHz 正弦交流电流



5.4 Standard charge process 标准充电流程

Battery cell is charged by 600mA constant current at $23\pm 3^{\circ}\text{C}$ until 4.35V. Then battery cell is charged by constant voltage at 4.35V until current drop to 24mA.

在 $23^{\circ}\text{C}\pm 3^{\circ}\text{C}$, 电池以 600mA 恒流电流充电直到 4.35V, 电池用 4.35V 恒压充电直到电池电流降到 24mA。

5.5 Standard discharge process 标准放电流程

Battery cell is discharged by 240mA continuous current at $23\pm 3^{\circ}\text{C}$ until the voltage drop to 2.75V.

在 $23^{\circ}\text{C}\pm 3^{\circ}\text{C}$, 电池以 240mA 连续放电电流放电直到 2.75V。

5.6 Rapid charge process 快速充电流程

Battery cell is charged by 1200mA constant current at $23\pm 3^{\circ}\text{C}$ until 4.35V. Then, battery cell is charged by constant voltage at 4.35V until current drop to 24mA.

在 $23^{\circ}\text{C}\pm 3^{\circ}\text{C}$, 电池以 1200mA 恒流电流充电直到 4.35V, 电池用 4.35V 恒压充电直到电池电流降到 24mA。

5.7 Rapid discharge process 快速放电流程

Battery cell is discharged by 600mA continuous current at $23\pm 3^{\circ}\text{C}$ until the voltage drop to 2.75V.

在 $23^{\circ}\text{C}\pm 3^{\circ}\text{C}$, 电池成品以 600mA 连续放电电流放电直到 2.75V。

5.8 Initial impedance 初始内阻值

Battery cell is fully charged by standard charge process.

The impedance of fully charged battery cell is tested by AC impedance tester at 1kHz. The initial impedance should be $\leq 65\text{m}\Omega$.

电池用标准充电流程充满电。再使用交流阻抗测试仪 (at 1KHz) 测量初始内阻。电池初始内阻应 $\leq 65\text{m}\Omega$ 。

5.9 Initial capacity 初始容量值

Battery cell is fully charged by standard charge process and then battery cell is fully discharged by standard discharge process. The initial capacity is ≥ 1200 mAh.

电池用标准充电流程充满电，再用标准放电流程放完电。电池初始容量 ≥ 1200 mAh。

5.10 Cycle life 循环寿命

Test procedure 测试步骤:

Step 1: Battery cell is charged by 1200mA constant current at $23\pm 3^{\circ}\text{C}$ until 4.35V. Then, battery cell is charged by constant voltage at 4.35V until current drop to 24mA.

Step 2: Wait for 10mins.

Step 3: Battery cell is discharged by 600mA continuous current at $23\pm 3^{\circ}\text{C}$ until the voltage drop to 2.75V.

Step 4: Wait for 10mins.

Step 5: Repeat step1 to step 4 until discharge capacity is less than 80% of initial battery capacity. Cycle life should be more than or equal to 500 cycles.

- 1) 电池成品在 $23\pm 3^{\circ}\text{C}$ 按 1200mA 恒流充电直到 4.35V，再用 4.35V 恒压充电直到充电电流小于 24mA。
- 2) 等待 10 分钟。
- 3) 电池成品在 $23\pm 3^{\circ}\text{C}$ 按 600mA 恒流放电直到 2.75V。
- 4) 等待 10 分钟。
- 5) 重复 1) 到 4)，直到放电容量小于初始容量 80%。

循环寿命需要 ≥ 500 周。



6. Usage of battery 使用电池

Shenzhen CoinCell Battery Co., Ltd. Ltd **DO NOT** take responsibility if customer **DO NOT** follow the specification and below instruction using the battery. 如果客户**没有**按规格书和以下说明使用电池，广东科恩瑟尔将**不负**任何责任。

To have good performance of battery, battery should follow this battery specification to use and storage.

Recommend to charge battery every 6 months using standard charge process.

To use the battery safe, battery is prohibited to disassemble, drop, heat, burn, soak, crush, shock, short circuit. Enough insulation inside the customer's end product is required to avoid the short circuit of the battery. Battery should have enough space to install inside the customer's end product. Please use the maximum dimension of battery after cycle life to reserve the space.

To protect the battery, battery should be installed in the customer's end product with strong mechanical strength.

Any movement of the battery in the end product should be avoided.

If battery has any abnormal feature such as battery cannot be charged and discharged, abnormal heat generate, deformation, smelling of electrolyte or leakage, battery should be stopped to use immediately. Battery with smelling of electrolyte or leakage should be placed away from fire. Electrolyte is harmful. If electrolyte is contacted the skin or eyes, please flush electrolyte by purified water and consult doctor. 为了电池保持良好的性能，电池需要按本规格书使用和储存。建议电池每 6 个月按标准充电流程充电一次。为了安全使用电池，电池禁止拆解，掉落，加热，焚烧，浸泡，挤压，撞击，短路。客户终端产品需要有足够的绝缘，避免电池被短路。

客户终端产品需要有足够的空间组装电池。空间需求请按规格书中循环后的电池成品最大尺寸进行设计。客户终端产品需要有强力的结构保护电池。请避免电池在客户终端产品中能移动。如果电池有异常特征，比方说电池不能充放电，发热异常，变形，有电解液气味或漏液，电池应马上停止使用。电池有电解液气味或漏液须要远离火种。电解液是有害的。如果电解液接触到皮肤或眼睛，请马上用纯净水冲洗和就医。

7. Warranty 保证期

Shenzhen CoinCell Battery Co., Ltd. guarantees the battery at good condition within **12 months** when battery is delivered from Shenzhen CoinCell Battery Co., Ltd. factory.

深圳市科恩瑟尔电池有限公司保证电池从出厂日起 **12 个月内**功能良好

8. Others 其他

8.1 Prohibition disassemble 禁止拆卸

- 1) Never disassemble the cells. The disassembling may generate internal short circuit in the cell, which may cause gassing, firing, explosion, or other problems.
 - 2) Electrolyte is harmful. If electrolyte is contacted the skin or eyes, please flush electrolyte by purified water and consult doctor.
- 1) 不要拆卸电池。拆卸电池会发生电池内部短路，会引起起火、爆炸、有害气体或者其它问题。
- 2) 电解液是有害的。如果电解液沾到皮肤、进入眼睛，应立即用清水冲洗以及求助医生。

8.2 Prohibition of dumping of battery into fire 不要把电池倾倒入火中

Never incinerate nor dispose the cells in fire. These may cause explosion of the cells, which is very Dangerous and is prohibited. 不要焚烧电池，否则会致电池爆炸，这很危险，必须禁止。

8.3 Prohibition of use of damaged battery 禁止使用损坏的电池

The cells might be damaged during shipping by shock. If any abnormal features of the cells are found such as damages in a plastic envelop of the cell, deformation of the cell package, smelling of an electrolyte, an electrolyte leakage and others, the cells shall never be used any more. The Cells with a smell of the electrolyte or a leakage shall be placed away from fire to avoid firing or explosion.

电池可能在出货途中碰撞而受损。如果发现电池有异常，例如包装损坏、电池包裹变形，有电解液的味道、发现漏液等等，不要再使用这些电池。电池如果有电解液的味道或者出现漏液，电池放置应该远离火源避免起火及爆炸。

8.4 The following warning language is to be provided with the information packaged with the small cells and batteries or equipment using them

以下警告语言将提供与小型电池、电池或设备一起使用的信息：

Keep batteries out of reach of children to avoid being swallowed, Swallowing may lead to burns, perforation of soft tissue, and death. Severe burns can occur within 2 h of ingestion. In case of ingestion of a cell or battery, seek medical assistance promptly.

把电池放到小孩够不到的地方以免吞服，吞下可能导致烧伤，软组织穿孔和死亡。如摄入电池，应立即寻求医疗救助，2小时内未进行处理可能会导致严重灼伤。

If children use the battery, their guardians should explain the proper handling. 小孩使用电池时，监护人应详细解释操作方法。

8.5 Any other items are not covered in the specification shall be agreed by both parties. 任何本规格书没有包括的事项，需要双方协议确定。